



TLC005981

Ka-Band MMIC Oscillator

Description

The TLC005981 is a general purpose MMIC oscillator with an output buffer amplifier. A 0.25 μm PHEMT process was chosen to provide 16 dBm of output power at 30 GHz and low power consumption. The center frequency is mechanically tunable by plucking airbridges. Additional ports are provided for varactor tuning up to 2 GHz.

Features

- ❑ 0.25mm PHEMT Process
- ❑ 25 to 35 GHz
- ❑ Up to 2 GHz varactor tuning
- ❑ $P_{\text{OUT}} = 16 \text{ dBm}$
- ❑ Chip Dimensions 2.17 x 1.3 x 0.1 mm

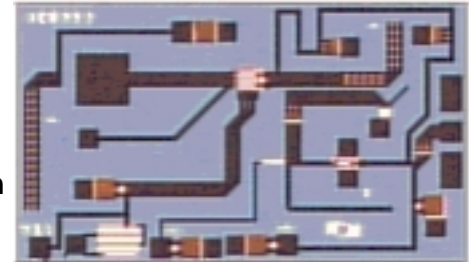

Absolute Maximum Ratings

Symbol	Parameter	Rating
V_D	Positive Supply Voltage	6 V
V_G	Negative Supply Voltage	-2 V
I_D	Positive Supply Current	200 mA
V_{DIODE}	Diode Supply Voltage	-20 V
T_C	Operating Temperature	-50 to 130 °C
T_{STG}	Storage Temperature	-65 to 150 °C

Performance Summary

(At 25 C, 50 ohm system)	Min	Typ	Max	
Frequency	25		35	GHz
P_0	12	16		dBm
$P_N(\text{dBc/Hz @ 1 MHz})$		-80		
Freq Change vs. Temp	60	75	100	KHz/°C
Drain Supply Voltage	3	5		V
Gate Supply Voltage	-1.5	-1	-0.5	V
Drain Supply Current	75	100	150	mA
Diode Supply Voltage	-18		0	V

TLC reserves the right to change performance data and specifications without notice



TLC005981

Ka-Band MMIC Oscillator

Recommended Operating Procedure

1. Apply gate supply voltage of -0.5 V to V_G .
2. Increase V_D to recommended operating voltage.
3. Vary V_{DIODE} for VCO operation.
4. Vary V_G for optimum power.
5. Turn off in the following sequence:
 - i. Turn off diode supply voltage (V_{DIODE})
 - ii. Turn off drain supply voltage (V_D)
 - iii. Turn off gate supply voltage (V_G)

MMIC Layout and Bond Pad Locations

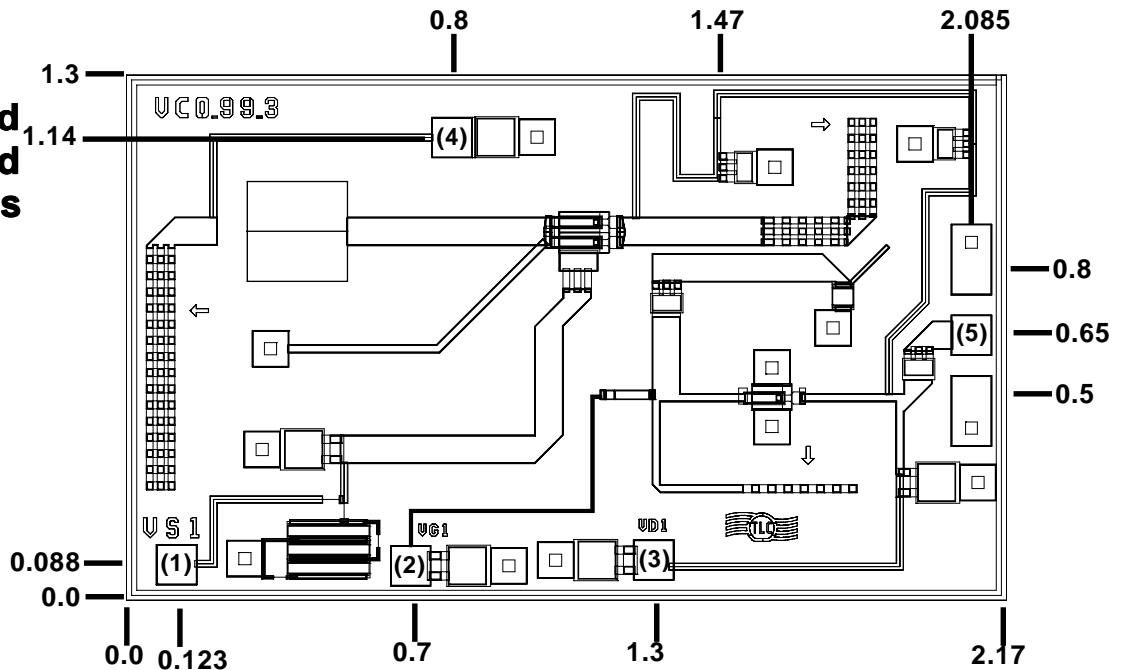

Units: millimeters

- Bond Pad 1 (V_{SOURCE})₁ 0.1x0.1
- Bond Pad 2 (V_G) 0.1x0.1
- Bond Pad 3 (V_D) 0.1x0.1
- Bond Pad 4 (V_{DIODE}) 0.1x0.1
- Bond Pad 5 (RF Output) 0.1x0.1

TLC reserves the right to change performance data and specifications without notice



TLC005981

Ka-Band MMIC Oscillator

1. VSOURCE pad is optional.
This data sheet does not cover its use. For more information, please contact TLC.

Recommended Assembly Diagram

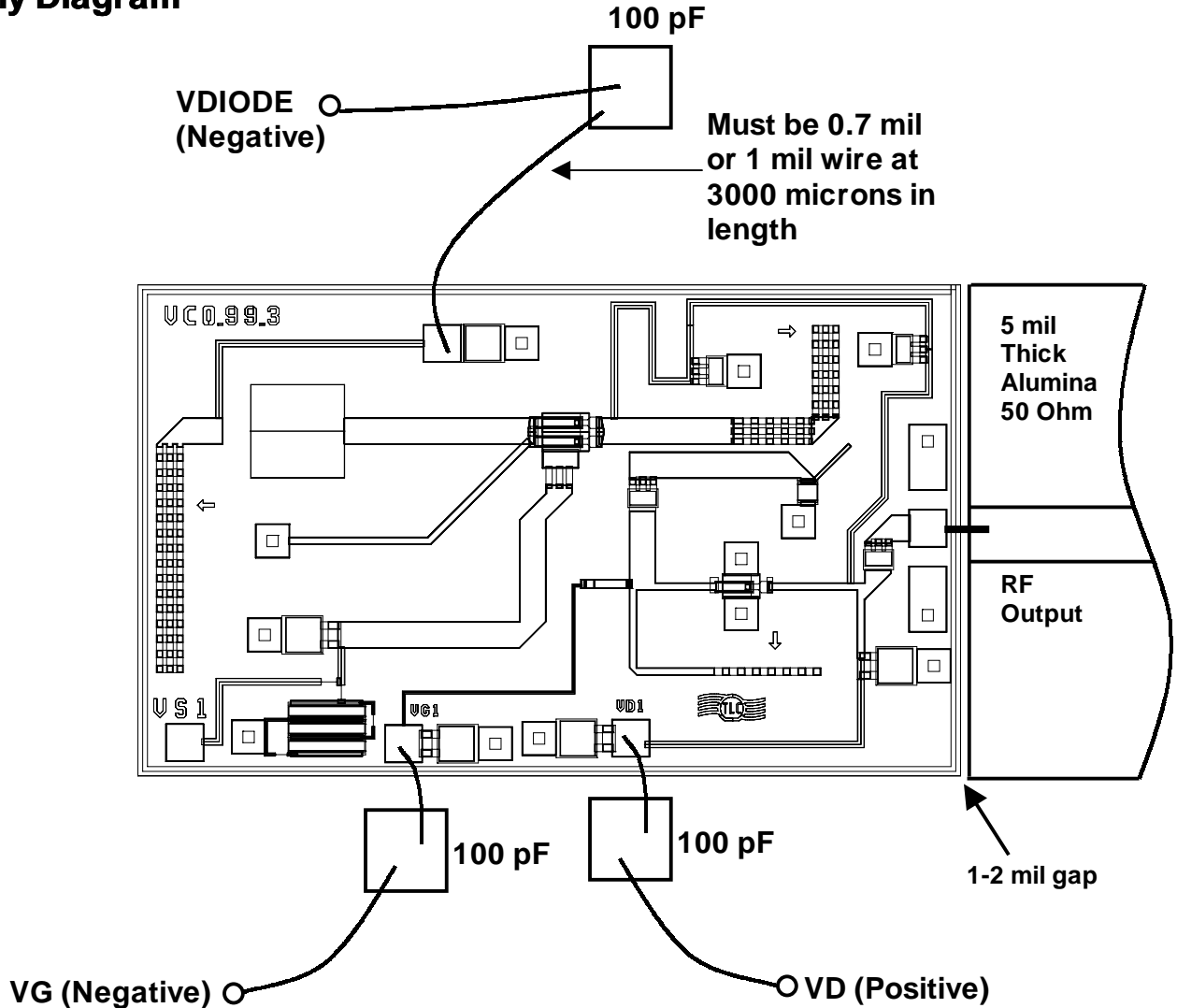

Note: Use one (1) 0.003" by 0.0005" gold ribbon or two (2) 0.0007" wire for bonding the RF input and output. Mount chip using silver epoxy (e.g. Epo-Tek H32C) or Gold-Tin (AuSn:80/20) solder. For best heat sinking, use either gold plated copper or composite matrix material, e.g. Thermocon.

TLC reserves the right to change performance data and specifications without notice



TLC005981

Ka-Band MMIC Oscillator

Performance Data

Diode Voltage vs Frequency

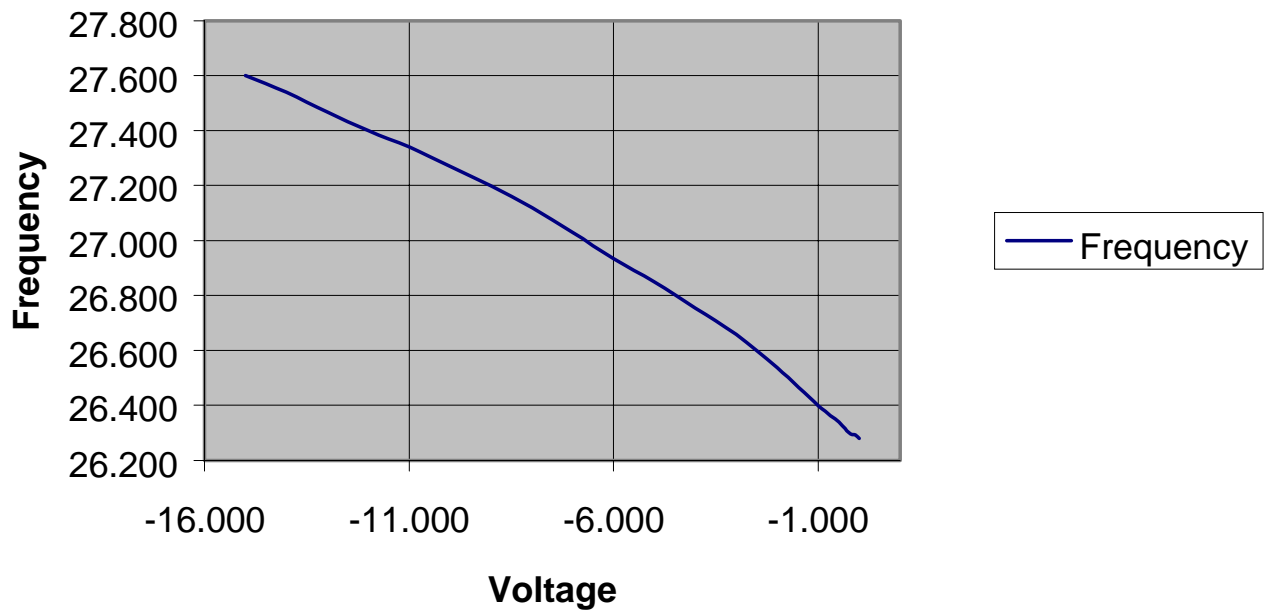

TLC reserves the right to change performance data and specifications without notice



TLC005981

Ka-Band MMIC Oscillator

Performance Data

Tuning Information

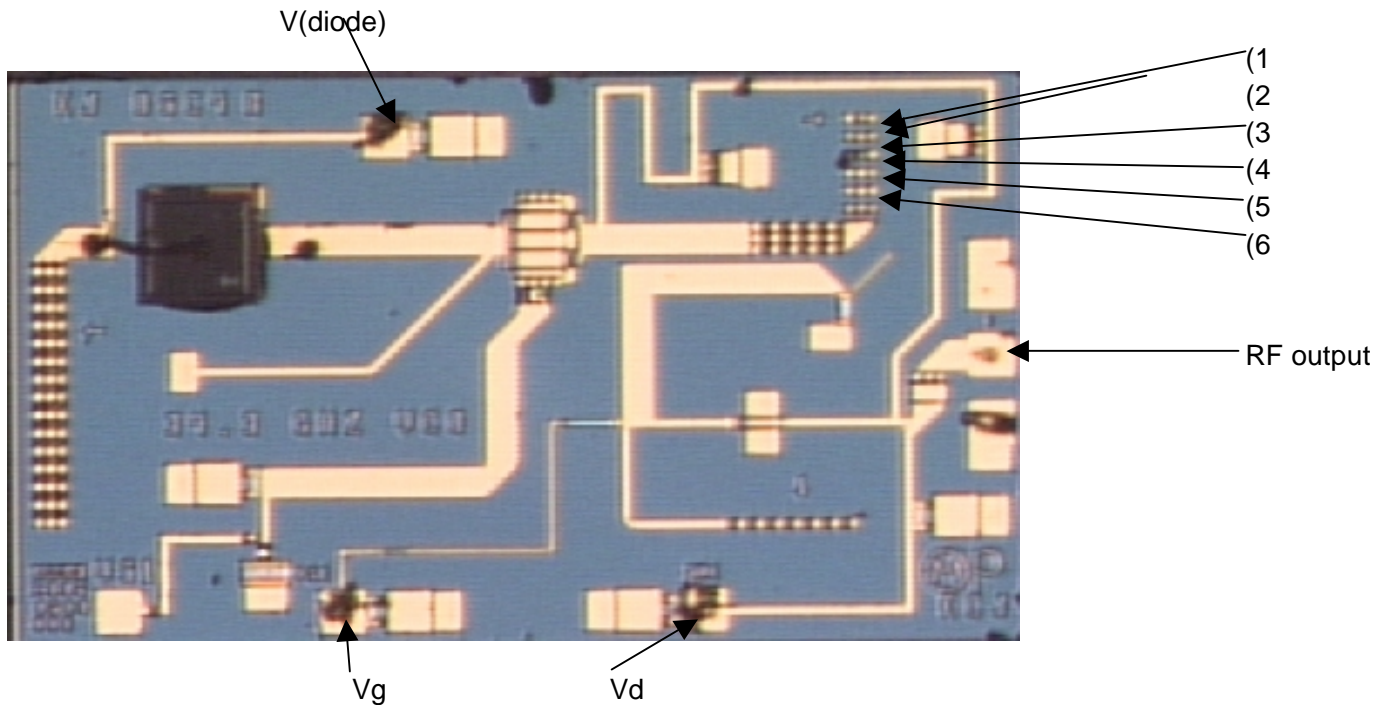

* denotes air bridge mechanical "pluck" location as shown in figure-1

Vg(osc)	Vd(ocs)	Id[mA]	V(diode)	P(out) dBm	Frequency (GHz)	Pluck Number
-4.5	5.03	102.3	0	-23	25.39	0
-4.5	5.03	102.3	-18	-13	27.57	0
-4.5	6.49	133.9	0	13.17	25.673	1*
-4.5	6.5	124.2	-18	13.83	27.946	1*
-3.87	6.5	136	0	13	25.859	2*
-4.49	5.51	111.5	-18	13	28.164	2*
-4.49	5.51	128	0	11.5	26.017	3*
-4.49	5.52	116.4	-18	13.5	28.397	3*
-2.53	5.5	137.9	0	11.67	26.2	4*
-2.53	5.5	125.9	-18	13.6	28.62	4*
-2.08	5.53	139	0	13.33	26.404	5*
-2.08	5.53	126.6	-18	13.5	28.5	5*
-2.66	5.6	145	0	12.83	26.533	6*
-2.66	5.6	140.5	-18	13.5	29.02	6*

TLC reserves the right to change performance data and specifications without notice